

The Slowest Water Exchange at a Homoleptic Mononuclear Metal Center: Variable-Temperature and Variable-Pressure ^{17}O NMR Study on $[\text{Ir}(\text{H}_2\text{O})_6]^{3+}$

Antonio Cusanelli, Urban Frey, David T. Richens,[#] and André E. Merbach*

Contribution from the Institut de Chimie Minérale et Analytique, Université de Lausanne-Bâtiment de Chimie (BCH), CH-1015 Lausanne-Dorigny, Switzerland

Received December 4, 1995[⊗]

Abstract: The rate constants and activation parameters for water exchange on hexaaqua and monohydroxy pentaqua iridium(III) have been determined by ^{17}O NMR spectroscopy as a function of temperature (358–406 K) and pressure (0.1–210 MPa) at several acidities (0.5–5.0 *m*). Noncoordinating trifluoromethanesulfonate (CF_3SO_3^-) was used as the counterion. The observed rate constant was of the form $k = k_1 + k_2/[\text{H}^+]$, where the subscripts 1 and 2 refer to the exchange pathways on $[\text{Ir}(\text{H}_2\text{O})_6]^{3+}$ and $[\text{Ir}(\text{H}_2\text{O})_5(\text{OH})]^{2+}$, respectively. The kinetic parameters obtained are summarized as follows: $k_1^{298} = (1.1 \pm 0.1) \times 10^{-10} \text{ s}^{-1}$, $\Delta H_1^\ddagger = 130.5 \pm 0.6 \text{ kJ mol}^{-1}$, $\Delta S_1^\ddagger = +2.1 \pm 1.7 \text{ J K}^{-1} \text{ mol}^{-1}$, and $\Delta V_1^\ddagger = -5.7 \pm 0.5 \text{ cm}^3 \text{ mol}^{-1}$; $k_2^{298} = (1.4 \pm 0.6) \times 10^{-11} \text{ m s}^{-1}$, $\Delta H_2^\ddagger = 138.5 \pm 4.5 \text{ kJ mol}^{-1}$, $\Delta S_2^\ddagger = +11.5 \pm 11.6 \text{ J K}^{-1} \text{ mol}^{-1}$, and $\Delta V_2^\ddagger = -0.2 \pm 0.8 \text{ cm}^3 \text{ mol}^{-1}$. The value obtained for k_1^{298} corresponds to a residence time of *ca.* 300 years. The $\text{p}K_a^{298}$ and the volume change ΔV_a^0 associated with the first hydrolysis of $[\text{Ir}(\text{H}_2\text{O})_6]^{3+}$ were determined by potentiometric and high-pressure spectrophotometric methods to be 4.45 ± 0.03 and $-1.5 \pm 0.3 \text{ cm}^3 \text{ mol}^{-1}$, respectively. Utilizing the relation $k_2 = k_{\text{OH}}K_{a1}$, values for the first-order rate constant and the corresponding activation volume for $[\text{Ir}(\text{H}_2\text{O})_5(\text{OH})]^{2+}$ were estimated to be $k_{\text{OH}}^{298} = 5.6 \times 10^{-7} \text{ s}^{-1}$ and $\Delta V_{\text{OH}}^\ddagger = +1.3 \text{ cm}^3 \text{ mol}^{-1}$, respectively. These data are supportive of an associative interchange (I_a) mechanism for water exchange on $[\text{Ir}(\text{H}_2\text{O})_6]^{3+}$, but of an interchange (I) mechanism on the deprotonated species $[\text{Ir}(\text{H}_2\text{O})_5(\text{OH})]^{2+}$. These mechanistic results have also been compared to those reported for other trivalent metal ions.

Introduction

Ever since the pioneering work of Eigen and Wilkins,^{3–5} which showed that, for aqueous solutions, the rates and activation parameters for ligand substitution were closely similar to those of solvent exchange, the study of the latter process has assumed fundamental importance. Accordingly, interest in the water exchange process has blossomed over the years resulting in one of the largest compilations of information about ligand substitution to date, encompassing an 18 order variation in the magnitude of the water exchange rate constant (Figure 1).

Among the earliest reported examples of solvent exchange kinetics was the work carried out by Hunt and Taube^{6,7} on the hexaaqua chromium(III) ion $[\text{Cr}(\text{H}_2\text{O})_6]^{3+}$. Their efforts established that this ion is capable of exchanging its bound water with solvent, although the rate of this exchange was extremely slow. Subsequently, the hexaaqua ion of rhodium was shown to be even more inert, and kinetic parameters and solvent exchange mechanisms for both acidic chromium(III) and rhodium(III) have now been proposed.^{8–11} Interestingly, despite much effort little is currently known about the kinetics of water

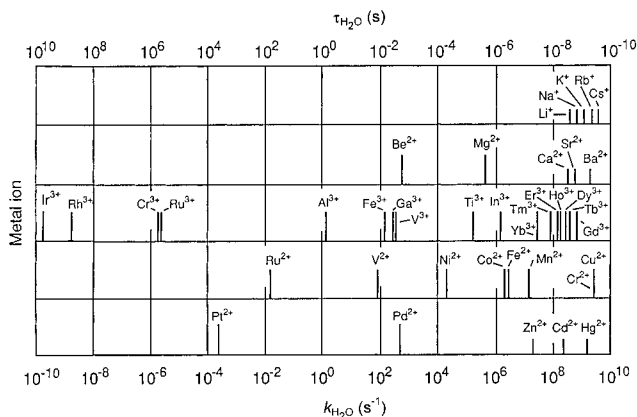

Figure 1. Mean lifetimes of a particular water molecule in the first coordination sphere of a given metal ion, $\tau_{\text{H}_2\text{O}}$, and the corresponding water exchange rate constants, $k_{\text{H}_2\text{O}}$. The tall bars indicate directly determined values whereas the short bars represent values deduced from complex formation studies.

exchange for the third-row ion, namely the hexaaqua complex of iridium(III). This lack of kinetic information for $[\text{Ir}(\text{H}_2\text{O})_6]^{3+}$ has been ascribed to its high degree of inertness toward ligand substitution, necessitating the need for extreme temperatures to promote solvent exchange, leading in turn to potential engineering or chemical problems (i.e., $[\text{Ir}(\text{H}_2\text{O})_6]^{3+}$ has been shown to be susceptible to oxidation and possibly oligomerization at high temperature).^{12–14} Using specifically designed high-temperature and high-pressure equipment, developed in-house, we have been

* Author to whom correspondence should be addressed.
[#] Permanent address: Department of Chemistry, The Purdie Building, University of St. Andrews, Scotland KY16 9ST.

[⊗] Abstract published in *Advance ACS Abstracts*, May 15, 1996.
 (1) High Pressure NMR Kinetics. Part 71. For part 70 see ref 2.
 (2) Töth, E.; Vauthey, S.; Pubanz, D.; Merbach, A. E. *Inorg. Chem.* In press.
 (3) Eigen, M. Z. *Elektrochem.* **1960**, *64*, 115.
 (4) Eigen, M. *Pure Appl. Chem.* **1963**, *6*, 97.
 (5) Eigen, M.; Wilkins, R. G. *Adv. Chem. Ser.* **1965**, No. 49, 55.
 (6) Hunt, J. P.; Taube, H. *J. Chem. Phys.* **1950**, *18*, 757.
 (7) Hunt, J. P.; Taube, H. *J. Chem. Phys.* **1951**, *19*, 602.
 (8) Stranks, D. R.; Swaddle, T. W. *J. Am. Chem. Soc.* **1971**, *93*, 2783.
 (9) Xu, F.-C.; Krouse, H. R.; Swaddle, T. W. *Inorg. Chem.* **1985**, *24*, 267.
 (10) Plumb, W.; Harris, G. M. *Inorg. Chem.* **1964**, *3*, 542.

(11) Laurency, G.; Rapaport, I.; Zbinden, D.; Merbach, A. E. *Magn. Reson. Chem.* **1991**, *29*, S45.
 (12) Castillo-Blum, S. E.; Richens, D. T.; Sykes, A. G. *J. Chem. Soc., Chem. Commun.* **1986**, 1120.
 (13) Castillo-Blum, S. E.; Sykes, A. G.; Gamsjäger, H. *Polyhedron* **1987**, *6*, 101.

able to solve these problems, and hence we now report the first definitive quantitative study of the water exchange process on iridium(III). Specifically, the rate constants and activation parameters for water exchange on hexaaqua and monohydroxy pentaqua iridium(III) have been determined by ^{17}O NMR spectroscopy as a function of temperature (358–406 K) and pressure (0.1–210 MPa) at several acidities (0.5–5.0 *m*) and a plausible mechanism for the exchange process proposed. Notably, the rate constant obtained for water exchange on hexaaqua iridium(III) ($1.1 \times 10^{-10} \text{ s}^{-1}$; residence time ≈ 300 years) corresponds to the *slowest* reported water exchange at a homoleptic mononuclear metal center to date, and thus a further expansion of Figure 1.⁴

Experimental Section

General Methods and Syntheses. All manipulations were performed under nitrogen or argon by using standard Schlenk or vacuum line techniques unless stated otherwise. Solutions of hexaaqua iridium(III) were prepared by slight modification to the literature method.¹⁵ Bi-distilled water was used as the solvent for the preparative procedures, as well as the variable-temperature and pressure NMR work. Trifluoromethanesulfonic acid (Ventron) was distilled at reduced pressure. Sodium hexachloroiridate(IV) (Johnson Matthey), 70% perchloric acid (Merck), sodium perchlorate (Aldrich), sodium trifluoromethanesulfonate (Aldrich), ascorbic acid (Aldrich), sodium hydroxide (Merck), ^{17}O -enriched water (3 atom %) (Yeda, Israel), and Dowex 50W-X2 cation exchange resin (Fluka) were used as received. All parameters reported were calculated with the data points weighted as $(Y_{\text{measured}} - Y_{\text{calculated}})^2 / (Y_{\text{measured}})^2$ and the reported errors are one standard deviation (1σ) unless stated otherwise. The iridium(III) solutions were prepared as molalities (*m*) for the variable-temperature and pressure NMR work and as molarities (*M*) for the acid dissociation measurements.

Preparation of $[\text{Ir}(\text{H}_2\text{O})_6]\text{X}_3$ ($\text{X} = \text{CF}_3\text{SO}_3^-$ (1) or ClO_4^- (2)). $\text{Na}_2[\text{IrCl}_6] \cdot 6\text{H}_2\text{O}$ (2.0 g, 3.6 mmol) was treated with a deoxygenated solution of 0.2 *m* sodium hydroxide (1000 mL) at 313 K for *ca.* 5 h. After 2 h, ascorbic acid (0.2 g) was added to the stirred iridium solution to prevent atmospheric oxidation. Adjustment of the solution to pH 6 by dropwise addition of $\text{CF}_3\text{SO}_3\text{H}$ or HClO_4 (2.0 *m*) then gave a precipitate of iridium(III) hydroxide hydrate $[\text{Ir}(\text{H}_2\text{O})_3(\text{OH})_3]$. The solution was then concentrated by rotary evaporation and the precipitate washed with bi-distilled water (2×100 mL). The precipitate was dissolved in $\text{CF}_3\text{SO}_3\text{H}$ or HClO_4 (0.1 *m*) and the resulting solution was loaded onto a Dowex 50W-X2 cation exchange column (10 cm \times 1 cm). Elution with $\text{CF}_3\text{SO}_3\text{H}$ or HClO_4 (2.0 *m*) afforded 1 in 43% yield (1.1 g, 1.5 mmol) or 2 in 34% yield (0.7 g, 1.2 mmol) as checked by UV/visible absorption spectroscopy.¹²

Preparation of $[\text{Ir}(\text{H}_2^{17}\text{O})_6](\text{CF}_3\text{SO}_3)_3$. A solution of $[\text{Ir}(\text{H}_2\text{O})_6](\text{CF}_3\text{SO}_3)_3$ was prepared by dissolving $[\text{Ir}(\text{H}_2\text{O})_3(\text{OH})_3]$ (2.0 g) in a 1.0 *m* solution of $\text{CF}_3\text{SO}_3\text{H}$ in ^{17}O -enriched water (3 atom %) and then placed in a sapphire NMR tube (see below for a detailed description of this equipment) under an argon atmosphere. The sapphire tube was then immersed in a silicone oil bath and the solution was heated at 413 K for 24 h to allow complete enrichment of the iridium first coordination sphere. This solution was then diluted with bi-distilled H_2O (*ca.* 30 mL) and then loaded onto a Dowex 50W-X2 cation exchange column (10 cm \times 1 cm). Elution with 2.0 *m* $\text{CF}_3\text{SO}_3\text{H}$ yielded the enriched complex $[\text{Ir}(\text{H}_2^{17}\text{O})_6](\text{CF}_3\text{SO}_3)_3$ (1- ^{17}O) as checked by UV/visible absorption spectroscopy. Stock solutions of $[\text{Ir}(\text{H}_2\text{O})_6]^{3+}$ were prepared from the strongly acid eluate by reprecipitating $[\text{Ir}(\text{H}_2\text{O})_3(\text{OH})_3]$ with NaOH at pH 6 and subsequently dissolving it in the appropriate amount of $\text{CF}_3\text{SO}_3\text{H}$ (0.5, 1.0, 1.5, 3.0, and 5.0 *m*). The solutions were stored under an argon atmosphere at 255 K to prevent oxidation to oligomeric products.

NMR Measurements. All the NMR samples were 0.03 *m* in Ir^{3+} . Four concentrations of $\text{CF}_3\text{SO}_3\text{H}$ (1.0, 1.5, 3.0, and 5.0 *m*) were used for the variable-temperature kinetic studies, whereas three concentrations of $\text{CF}_3\text{SO}_3\text{H}$ (0.5, 1.0, 5.0 *m*) were used for the variable-pressure

measurements. For all the NMR kinetic measurements the ionic strength was maintained constant at 5.1 *m* with NaCF_3SO_3 . Oxygen-17 NMR spectra were recorded on a Bruker AM 400 instrument equipped with a wide-bore cryomagnet (9.4 T) at an operating frequency of 54.2 MHz. ^{17}O NMR chemical shifts are reported with respect to an internal reference of neat H_2O (solvent).

Variable-temperature (ambient pressure) kinetic measurements were conducted at four temperatures. At 406.3 K, the kinetics were followed in a commercial broad-band probe thermostated with a Bruker B-VT 2000 unit, and the temperature was found to be constant to within ± 0.2 K as measured by a substitution technique using a platinum resistor.¹⁶ At this temperature the sample was housed in a sapphire NMR tube and a Teflon plug was inserted into the tube to ensure that the refluxing water solution remained in the lower 3 cm of the tube, between the receiver coils of the NMR probe. At 392.6, 372.8, and 358.2 K the water exchange kinetics are extremely slow and thus the samples, which were contained in sapphire NMR tubes, were stored in a thermostated bath and transferred at measured intervals into the NMR probe. The spectra were then recorded at ambient temperature since the water exchange is effectively quenched at this temperature.

Variable-pressure kinetic measurements obtained at 358.2 K were conducted at 0.1 (ambient pressure), 70, 140, and 210 MPa. For these very slow high-pressure water exchanges, the samples, contained in deformable cylindrical thin-walled Teflon cells (8.5-mm outside diameter and 33-mm length), were kept in stainless-steel pressure vessels which were in turn immersed in a thermostated bath. For the NMR measurements, the pressure was released at fixed intervals, the Teflon cells placed into conventional 10-mm Pyrex NMR tubes, and the spectra recorded. After the NMR measurements, the samples were repressurized and returned to the bath. The time of this operation was short compared to the half-life of the water exchange. Each kinetic run consisted of 12–15 spectra and was monitored for *ca.* 3 half-lives. The temperature of the thermostated bath, in all cases, was measured by a platinum resistor and was found to be constant to within ± 0.2 K.

Potentiometric and Spectrophotometric Measurements. The potentiometric experiments were carried out using a Metrohm Titrino DMS 716 titration instrument equipped with a Metrohm combined glass electrode, calibrated ($\text{pH} = -\log[\text{H}^+]$) by titration of $\text{CF}_3\text{SO}_3\text{H}$ with carbonate free NaOH ($\mu = 5.0$ M NaCF_3SO_3). For all the acid dissociation measurements the ionic strength was maintained constant at 5.0 M with NaCF_3SO_3 . The reproducibility of the pH measurements was ± 0.003 . Titrations with an NaOH solution ($[\text{OH}^-] = 1.251 \times 10^{-2}$ M; $\mu = 5.0$ M NaCF_3SO_3) were conducted in a cylindrical-shaped vessel, thermostated at 298.0 ± 0.1 K, on a solution which was 1.51×10^{-3} M in Ir(III) and 8.007×10^{-4} M in $\text{CF}_3\text{SO}_3\text{H}$ ($\mu = 5.0$ M NaCF_3SO_3 , $d = 1.39$ g cm^{-3}). The acidified solution of $[\text{Ir}(\text{H}_2\text{O})_6]^{3+}$ was titrated up to a mole fraction of $[\text{Ir}(\text{H}_2\text{O})_5(\text{OH})]^{2+}$ not exceeding 0.6. Under these conditions no precipitation occurred.

UV/visible spectra were obtained on acidified solutions of $[\text{Ir}(\text{H}_2\text{O})_6]^{3+}$ ($[\text{Ir}^{3+}] = 6.04 \times 10^{-3}$ M; $\mu = 5.0$ M NaCF_3SO_3) using a Perkin Elmer Lambda 19 double beam spectrophotometer. A 1-cm thermostated cell was used for the pH dependence measurements to maintain a temperature of 298.0 ± 0.1 K. For the variable-pressure experiments, a "Le Noble" piston-type cell (optical path length 1.920 cm) was used.¹⁷ The cell was immersed in the pressure transmitting fluid (water) inside a double beam pressurizable and thermostatable pressure bomb.¹⁷ The temperature was controlled by circulation of liquid from a thermostat bath and the temperature was measured using a Pt resistor placed in the body of the pressure bomb (298.0 ± 0.1 K). The pH was measured before and after the spectrophotometric measurements to ± 0.003 pH units with a Metrohm combined glass electrode calibrated in the same manner described previously. The potentiometric and spectrophotometric data were analyzed using the program PSEQUAD.¹⁸

Sapphire NMR Tubes. Sapphire NMR tubes, initially developed

(16) Ammann, C.; Meier, P.; Merbach, A. E. *J. Magn. Reson.* **1982**, *46*, 319.

(17) Richens, D. T.; Ducommun, Y.; Merbach, A. E. *J. Am. Chem. Soc.* **1987**, *109*, 603.

(18) Zékany, L.; Nagypal, I. In *Computational Methods for Determination of Formation Constants*; Legatt, D. J., Ed.; Plenum Press: New York, 1985; p 291.

(14) Castillo-Blum, S. E.; Richens, D. T.; Sykes, A. G. *Inorg. Chem.* **1989**, *28*, 954.

(15) Beutler, P.; Gamsjäger, H. *J. Chem. Soc., Chem. Commun.* **1976**, 554.

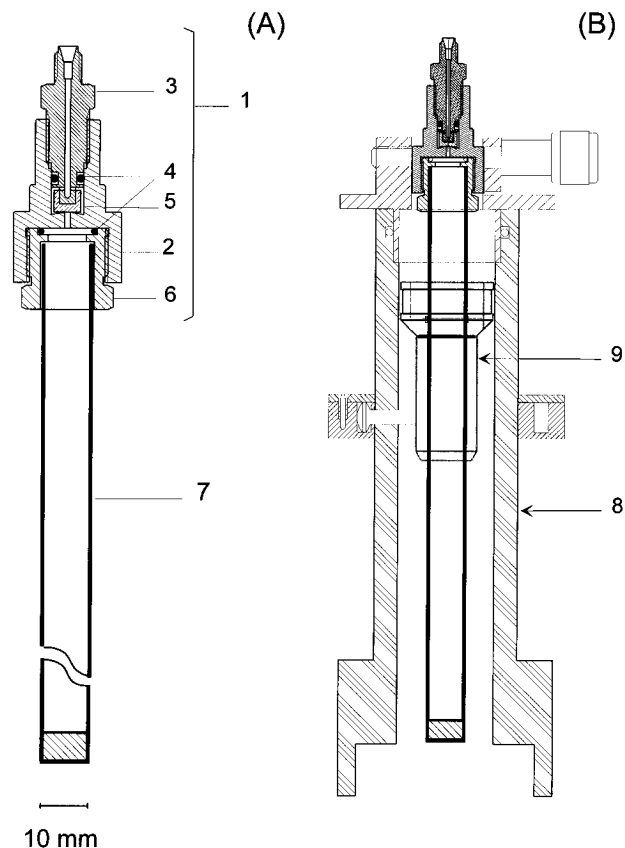

Figure 2. (A) Schematic drawing of the sapphire tube and valve assembly illustrating the Ti-alloy valve (1), valve body (2), valve stem (3), Viton O-ring (4), Vespel or KelF seal (5), tube mounting flange (6), and sapphire NMR tube (7). (B) Schematic drawing of the Plexiglass safety cylinder (8) used during the pressurization and transportation of the sapphire tube and the commercial spinner (9).

by Roe *et al.*¹⁹ and subsequently improved by Horváth *et al.*,²⁰ although widely used today for gas/liquid systems, are not particularly well-suited for solid systems because of their small valve opening which makes the weighing of solids and even liquids extremely difficult. To address this concern, we have redesigned the titanium valve to create a much larger valve opening and thus facilitate the introduction of material into the NMR tube as well as the cleaning of the tube. Furthermore, the centrosymmetric design and the lighter weight of our sapphire tube/valve system helps to dramatically minimize spinning side bands. This new generation of sapphire NMR tubes is particularly useful for obtaining NMR measurements at temperatures above the boiling point of the NMR solvent (i.e., autogenic pressures) and can also accommodate high pressures up to *ca.* 10 MPa.²¹

A schematic drawing of a 10-mm sapphire tube (Saphicon Inc., Milford, NH 03055) illustrating the newly designed valve is given in Figure 2A. The valve (1) consists of the valve body (2), the valve stem (3) with the Viton O-ring (4), the Vespel or KelF valve seal (5), and the sapphire tube mounting flange (6) with a second Viton O-ring (4). The sapphire tube (7) was affixed onto the mounting flange with the composite glue Araldit AV138M/hardener HV998. All metallic parts were constructed from titan grade 5 (6% Al, 4% V; Bibus Inco Alloys, CH-8126 Zumikon). The combined weight of the sapphire tube (10 mm outside diameter and 8 mm inside diameter) and the valve is 46 g, ensuring that once inserted into the NMR magnet the closed tube can be removed and spun with a slightly increased lift and spinner pressure.

Two 10-mm sapphire tubes were tested and found to withstand liquid (H₂O) pressures up to 55 MPa at which point the tube came apart from the mounting flange. A similar 5 mm outside diameter, 3.4 mm inside diameter sapphire tube was tested and found to withstand gas pressures

up to 80 MPa at which point the tube burst. Before the sapphire tubes are used they are always tested to ensure that they can support a liquid pressure of 20 MPa and a gas pressure (N₂) of 15 MPa. For safety reasons, the tubes are only used with pressures up to 10 MPa and are frequently retested using the procedure described previously.

A typical experimental protocol for the preparation of a sapphire NMR tube sample commences with the weighing of the solid and/or liquid sample directly into the sapphire tube and then the valve body and valve stem are screwed onto the tube mounting flange. Before pressurizing, the closed tube is adjusted to the correct height in a commercial ceramic spinner and then placed into a Plexiglas safety shield. A schematic drawing of the safety shield (8) with the tube and spinner (9) is shown in Figure 2B. The safety shield which was used in the burst test up to 80 MPa acquired only minor scratches, thus demonstrating that it is capable of providing maximum protection for the user during pressurizing and transportation of the closed sapphire tube. However, it is of utmost importance that the lower open part of the safety shield be directed toward the floor.

For experiments where gases are used, the gas inlet port is connected to a gas distribution system *via* a 1/16-in. swagelock. The sapphire tube is pressurized by turning the valve stem to the open position (1 turn). Once the desired pressure is reached, the valve stem is turned to the closed position and the tube is subsequently disconnected from the gas distribution system. To use the sapphire tube under autogenic pressures, the sample is simply introduced into the tube and the tube is then closed. As no pressure detector is incorporated into the sapphire tube, it is imperative that the phase diagram of the solvent (mixture) used be carefully examined prior to experimentation to ensure that the allowed pressure domain is not surpassed.

Results

Variable-Temperature Kinetics. The ¹⁷O enrichment of the bound water in the hexaaqua ion [Ir(H₂O)₆]³⁺ was accomplished by refluxing the iridium salt at 413 K for 24 h in an acidified solution of ¹⁷O-enriched water. This enrichment step was successful when the counterion was trifluoromethanesulfonate (CF₃SO₃⁻). However, repeating this procedure with perchlorate (ClO₄⁻) as the counterion led instead to the formation of a purple solution whose ¹⁷O NMR spectrum exhibited a single resonance at -10 ppm not assignable to the hexaaqua (-151 ppm) or ClO₄⁻ (290 ppm) oxygens. The UV/visible spectrum of this colored solution displayed a broad absorption band with a peak maximum at 547 nm. A ¹⁷O NMR spectrum of an isotopically equilibrated 0.03 *m* aqueous solution of [Ir(H₂O)₆](CF₃SO₃)₃ (3% oxygen-17) recorded at ambient temperature exhibited a single broad resonance (1/T₂ = 1894 s⁻¹ at 298 K) due to the ligated water at -151 ppm. This assignment was verified by acquiring a ¹⁷O NMR spectrum of a solution of the iridium(III) trifluoromethanesulfonate salt at natural abundance (0.037 atom %). The low frequency chemical shift obtained for this aqua ion is comparable to the bound water shifts of other low-spin diamagnetic t_{2g}⁶ metal ions such as [Rh(H₂O)₆]³⁺ or [Ru(H₂O)₆]²⁺,²² which exhibited ¹⁷O NMR resonances at -130.5 and -196.3 ppm, respectively. Notably, no significant temperature-dependence of the chemical shift was observed for [Ir(H₂O)₆](CF₃SO₃)₃.

The water exchange on [Ir(H₂O)₆]³⁺ (eq 1) was followed by

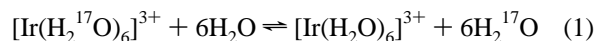

monitoring the depletion of the hexaaqua ion and the enrichment of bulk water in oxygen-17 with time. The rate law for the isotopic exchange illustrated in eq 1 can be expressed by eq 2,²³

(19) Roe, D. C. *J. Magn. Reson.* **1985**, *63*, 388.

(20) Horváth, I. T.; Ponce, E. C. *Rev. Sci. Instrum.* **1991**, *62*, 1104.

(21) Since dangerously high gas pressures are involved, safety precautions must be taken when handling the sapphire NMR tubes.

(22) Rapaport, I.; Helm, L.; Merbach, A. E.; Bernhard, P.; Ludi, A. *Inorg. Chem.* **1988**, *27*, 873.

(23) Helm, L.; Elding, L. I.; Merbach, A. E. *Inorg. Chem.* **1985**, *24*, 1719.

$$-dx/dt = k(x - x_\infty)/(1 - x_\infty) \quad (2)$$

where k represents the rate constant for the exchange of a particular water molecule,²⁴ and x and x_∞ represent the mole fractions of labeled water coordinated to the metal at the time of sampling and at the exchange equilibrium, respectively. The time dependence of the mole fraction x of ligated oxygen-17 water (Figure 3), obtained by integration of the resonances, was fitted to eq 3 which was arrived at by integration of eq 2 using $x = x_0$ at $t = 0$, and $x_\infty \approx 6 \times 0.03/55.5 \approx 0.003$.

$$x = x_\infty + (x_0 - x_\infty) \exp[-kt/(1 - x_\infty)] \quad (3)$$

The adjustable parameters were k and x_0 .

As previously documented for other trivalent aqua ions,^{11,22} the observed water exchange rate constant k was found to be acid dependent (see Figure 4A). This dependence can be rationalized as being composed of two contributions according to eq 4,

$$k = k_1 + k_2/[H^+] \quad (4)$$

where k_1 is the rate constant for water exchange on the hexaaqua ion $[\text{Ir}(\text{H}_2\text{O})_6]^{3+}$ and k_2 is the product (eq 5) of k_{OH} , the rate

$$k_2 = k_{\text{OH}}K_a \quad (5)$$

constant for water exchange on the monohydroxy pentaqua ion $[\text{Ir}(\text{H}_2\text{O})_5(\text{OH})]^{2+}$, and K_a , the first acid dissociation constant for $[\text{Ir}(\text{H}_2\text{O})_6]^{3+}$ (eq 6).

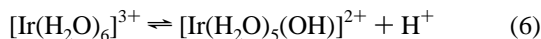

The treatment of kinetic data with respect to the rate constant k_2 has provided its share of controversy in the literature. Grant *et al.*²⁵ assumed that the hydroxo ligand does not contribute to the exchange in the case of Fe(III) and thus applied a statistical factor of $5/6$ to the rate coefficients. Contrary to this idea, it has also been suggested that a factor of $1/6$ should be applied if the hydroxo ligand specifically activates the water molecule *trans* to it,^{24,26} although direct evidence for such an activation may be difficult if not impossible to obtain given that the rate of proton exchange with the bulk water is most certainly much faster than the rate of the corresponding oxygen exchange. Given these contradictory approaches, we have assumed that all six oxygen atoms in the monohydroxy species contribute equally to the k_2 value. In any case, these considerations do not affect the calculation of either the volumes or enthalpies of activation.²⁷

The observed variable-temperature water exchange rate constants, obtained at four acid concentrations and four temperatures (Table 1), were least-squares fitted in a simultaneous fashion to eqs 4 and 7, and in turn, lead to the rate constants and activation parameters presented in Table 2.

$$k = (k_B T/h) \exp[(\Delta S^\ddagger/R) - (\Delta H^\ddagger/RT)] \quad (7)$$

Variable-Pressure Kinetics. The observed variable-pressure water exchange rate constants were obtained at three acidities and four pressures at 358.2 K (Table 3).

A simultaneous least-squares fit of the pressure data to eqs 4 and 8 (Figure 4A), then gave the rate constants and activation

$$\ln k_i = \ln k_{i,0} - \Delta V_i^\ddagger P/RT \quad (i = 1, 2) \quad (8)$$

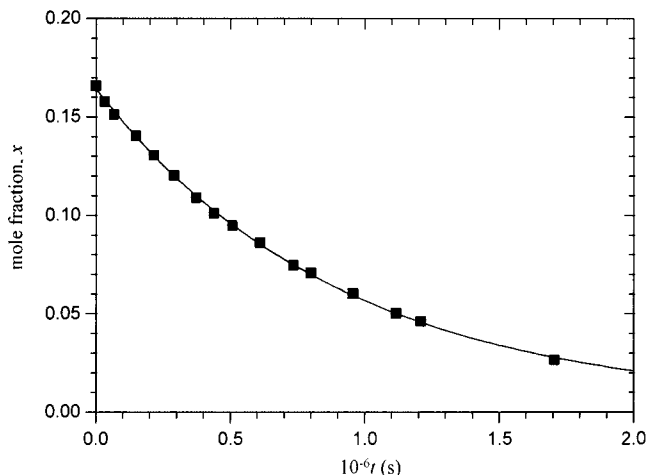

Figure 3. Mole fraction x of bound oxygen-17 water, as a function of time, as monitored by ^{17}O NMR spectroscopy for a solution of $[\text{Ir}(\text{H}_2\text{O})_6](\text{CF}_3\text{SO}_3)_3$ (3% oxygen-17) in 1.0 m $\text{CF}_3\text{SO}_3\text{H}$ at 358.2 K and ambient pressure ($[\text{Ir}^{3+}] = 0.03 m$; $\mu = 5.1 m$ NaCF_3SO_3).

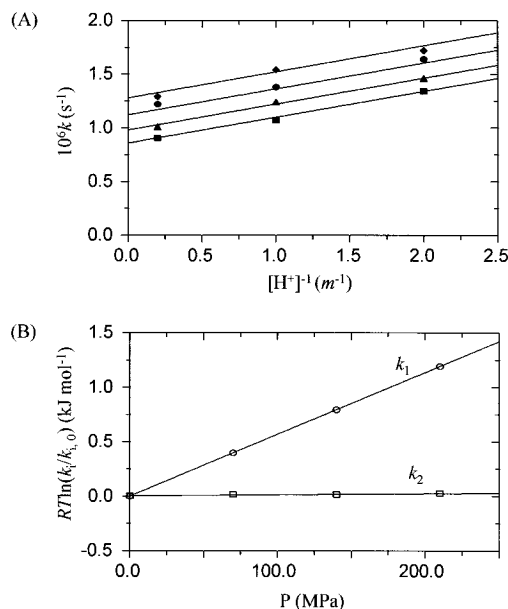

Figure 4. (A) Acid dependence of the observed water exchange rate constants k (s^{-1}) for 0.03 m $[\text{Ir}(\text{H}_2\text{O})_6]^{3+}$ solutions ($\mu = 5.1 m$ NaCF_3SO_3) at 358.2 K and various pressures: (■) 0.1, (▲) 70, (●) 140, and (◆) 210 MPa. (B) Effect of pressure on the water exchange rate constant for $[\text{Ir}(\text{H}_2\text{O})_6]^{3+}$ (○, k_1) and for $[\text{Ir}(\text{H}_2\text{O})_5(\text{OH})]^{2+}$ (□, k_2) at 358.2 K ($[\text{Ir}^{3+}] = 0.03 m$; $\mu = 5.1 m$ NaCF_3SO_3).

Table 1. Water Exchange Rate Constants for $[\text{Ir}(\text{H}_2\text{O})_6](\text{CF}_3\text{SO}_3)_3$, $10^6 k$ (s^{-1}), as a Function of Temperature and Acidity at Ambient Pressure^a

$[\text{CF}_3\text{SO}_3\text{H}]$ (m)	358.2 K	372.8 K	392.6 K	406.3 K
1.0	1.10 ± 0.01	6.42 ± 0.08	59.2 ± 0.8	237 ± 3
1.5	1.02 ± 0.01	6.11 ± 0.09	54.8 ± 0.4	217 ± 1
3.0	0.96 ± 0.01	5.85 ± 0.05	51.0 ± 0.3	199 ± 1
5.0	0.92 ± 0.01	5.64 ± 0.08	48.9 ± 0.3	191 ± 2

^a Concentration of $[\text{Ir}(\text{H}_2\text{O})_6](\text{CF}_3\text{SO}_3)_3$ was 0.03 m and its initial ^{17}O enrichment was 3% ($\mu = 5.1 m$ NaCF_3SO_3).

parameters presented in Table 2. The adjustable parameters were the activation volumes ΔV_i^\ddagger and the rate constants at zero pressure $k_{i,0}$ ($i = 1, 2$). The normalized natural logarithms of the rate constants as a function of pressure for both the hexaaqua ion $[\text{Ir}(\text{H}_2\text{O})_6]^{3+}$ and the monohydroxy pentaqua species $[\text{Ir}(\text{H}_2\text{O})_5(\text{OH})]^{2+}$, derived from the simultaneous least-squares fit of the pressure data to eqs 4 and 8 (Figure 4A), are shown in Figure 4B.

(24) Lincoln, S. F.; Merbach, A. E. *Adv. Inorg. Chem.* **1995**, *42*, 1.

(25) Grant, M.; Jordan, R. B. *Inorg. Chem.* **1981**, *20*, 55.

(26) Swaddle, T. W. *Adv. Inorg. Bioinorg. Mech.* **1983**, *2*, 95.

(27) Swaddle, T. W.; Merbach, A. E. *Inorg. Chem.* **1981**, *20*, 4212.

Table 2. Rate Constants, Activation Parameters, and Thermodynamic Parameters for Water Exchange on Hexaaqua and Monohydroxy Pentaqua Iridium(III)

species	parameter	value
[Ir(H ₂ O) ₆] ³⁺	k_1^{298} (s ⁻¹)	$(1.1 \pm 0.1) \times 10^{-10}$
	ΔH_1^\ddagger (kJ mol ⁻¹)	130.5 ± 0.6
	ΔS_1^\ddagger (J K ⁻¹ mol ⁻¹)	+2.1 ± 1.7
	ΔV_1^\ddagger (cm ³ mol ⁻¹)	-5.7 ± 0.5
	$k_{1,0}^{358}$ (s ⁻¹)	$(8.5 \pm 0.2) \times 10^{-7}$
[Ir(H ₂ O) ₅ (OH)] ²⁺	k_2^{298} (m s ⁻¹)	$(1.4 \pm 0.6) \times 10^{-11}$
	ΔH_2^\ddagger (kJ mol ⁻¹)	138.5 ± 4.5
	ΔS_2^\ddagger (J K ⁻¹ mol ⁻¹)	+11.5 ± 11.6
	ΔV_2^\ddagger (cm ³ mol ⁻¹)	-0.2 ± 0.8
	$k_{2,0}^{358}$ (m s ⁻¹)	$(2.4 \pm 0.2) \times 10^{-7}$
	k_2/k_1	$(1.2 \pm 0.6) \times 10^{-1}$
	pK_a^{298}	4.45 ± 0.03 ^a
	k_{OH}^{298} (s ⁻¹)	5.6×10^{-7}
	ΔV_a^0 (cm ³ mol ⁻¹)	-1.5 ± 0.3
	pK_a^0	4.45 ± 0.01
	ΔV_{OH}^\ddagger (cm ³ mol ⁻¹)	+1.3

^a Potentiometrically determined value.**Table 3.** Water Exchange Rate Constants for [Ir(H₂O)₆](CF₃SO₃)₃, 10⁶k (s⁻¹), as a Function of Pressure and Acidity at 358.2 K^a

[CF ₃ SO ₃ H] (m)	0.1 MPa	70 MPa	140 MPa	210 MPa
0.5	1.34 ± 0.02	1.46 ± 0.02	1.64 ± 0.02	1.72 ± 0.03
1.0	1.07 ± 0.01	1.24 ± 0.03	1.38 ± 0.02	1.54 ± 0.02
5.0	0.90 ± 0.01	1.01 ± 0.02	1.22 ± 0.02	1.29 ± 0.01

^a Concentration of [Ir(H₂O)₆](CF₃SO₃)₃ was 0.03 m and its initial ¹⁷O enrichment was 3% ($\mu = 5.1$ m NaCF₃SO₃).

Thermodynamics for the Acid Dissociation of [Ir(H₂O)₆]³⁺. To calculate the kinetically relevant values for water exchange on the monohydroxy species, the thermodynamic parameters associated with the acid dissociation of the hexaaqua ion were first determined. The equilibrium constant (K_a) for the acid dissociation reaction of [Ir(H₂O)₆]³⁺, represented in eq 6, was determined potentiometrically as well as spectrophotometrically.

The titration data obtained from three independent potentiometric trials was utilized simultaneously to give a pK_a^{298} value of 4.45 ± 0.03 (Table 2) which is in good agreement with the value of 4.37 measured by Gamsjäger *et al.* in 1.05 m NaClO₄.^{28,29} The spectrophotometric data, which were acquired over a pH range of 0.979–4.368 (Figure 5), lead to a pK_a^{298} value of 4.29 ± 0.05 . This estimate is in agreement, within error (assuming 2σ for the errors), to the potentiometrically determined value and thus further corroborates the validity of our results. This agreement is substantiated in Figure 5 which illustrates schematically the experimental spectrophotometric spectra and the absolute difference between these measurements and the calculated curves derived from the potentiometric pK_a^{298} value of 4.45. Included in this figure are the calculated limiting spectra for [Ir(H₂O)₆]³⁺ (peak maxima λ/nm ($\epsilon/M^{-1} \text{ cm}^{-1}$) at 262 (36.6) and 311 (30.8)) and for [Ir(H₂O)₅(OH)]²⁺ (peak maxima λ/nm ($\epsilon/M^{-1} \text{ cm}^{-1}$) at 266 (60.7) and 314 (43.5)). The experimentally determined rate constant k_2 , when combined with the first hydrolysis constant K_a (eq 5), yielded an estimate of $5.6 \times 10^{-7} \text{ s}^{-1}$ for k_{OH} , the rate constant for water exchange on the monohydroxy pentaqua ion [Ir(H₂O)₅(OH)]²⁺ (Table 2).

The volume change ΔV_a^0 accompanying the acid dissociation reaction in eq 6 was determined by observing the effect of pressure on the optical absorbance A due to [Ir(H₂O)₅(OH)]²⁺. A series of variable-pressure experiments up to 200 MPa at

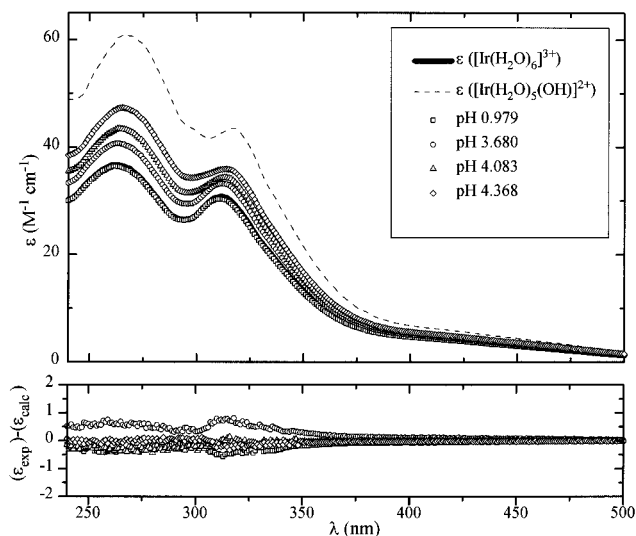
**Figure 5.** Experimental and calculated spectrophotometric spectra for [Ir(H₂O)₆]³⁺ and [Ir(H₂O)₅(OH)]²⁺ illustrating the absolute difference between the experimentally determined curves and those calculated using the potentiometrically determined pK_a^{298} value of 4.45.**Table 4.** Pressure Dependence of Absorbance (A) and Corresponding pK_a for [Ir(H₂O)₆](CF₃SO₃)₃^a

pressure (MPa)	A	pK_a
0.1	0.521	4.45
40	0.523	4.44
70	0.523	4.44
100	0.524	4.43
140	0.525	4.42
170	0.526	4.42
200	0.530	4.39

^a Obtained from a 6.04×10^{-3} M aqueous solution of [Ir(H₂O)₆](CF₃SO₃)₃ at 266 nm and at 298.0 K ($\mu = 5.0$ M NaCF₃SO₃).

298.0 K were conducted on a 6.04×10^{-3} M Ir(III) solution of pH 4.174. The spectra were taken at 100 and 200 MPa with increasing pressure and at 170, 140, 70, and 40 MPa with decreasing pressure. The pH of the solution, measured before and after the variable-pressure experiments, was unchanged. The absorbance changes with pressure, followed at 266 nm, were then converted to pK_a values (Table 4) using eq 9 where b is the optical path length (1.920 cm) and $\epsilon_{Ir^{3+}}$ and $\epsilon_{IrOH^{2+}}$ are the

$$A = b[\text{Ir(III)}][(\epsilon_{Ir^{3+}}) + (\epsilon_{IrOH^{2+}})(10^{\text{pH}-\text{p}K_a})]/(1 + 10^{\text{pH}-\text{p}K_a}) \quad (9)$$

molar absorptivities ($M^{-1} \text{ cm}^{-1}$) of the two species in equilibrium (i.e., [Ir(H₂O)₆]³⁺ and [Ir(H₂O)₅(OH)]²⁺, respectively). The pK_a values obtained in this manner were then fitted to eq 10, leading to a ΔV_a^0 value of $-1.5 \pm 0.3 \text{ cm}^3 \text{ mol}^{-1}$ and a pK_a^0 value of 4.45 ± 0.01 (Table 2).

$$pK_a = pK_a^0 + \Delta V_a^0 P / 2.303RT \quad (10)$$

The difference between the experimental volume of activation ΔV_2^\ddagger and the volume change ΔV_a^0 associated with the first hydrolysis of [Ir(H₂O)₆]³⁺ (eq 11) gave an estimate of +1.3

$$\Delta V_{OH}^\ddagger = \Delta V_2^\ddagger - \Delta V_a^0 \quad (11)$$

$\text{cm}^3 \text{ mol}^{-1}$ for ΔV_{OH}^\ddagger , the volume of activation for water exchange on the monohydroxy pentaqua species [Ir(H₂O)₅(OH)]²⁺ (Table 2).

Discussion

Synthesis and Characterization of [Ir(H₂O)₆](CF₃SO₃)₃. The perchlorate salt of hexaaqua iridium(III) was first character-

(28) Gamsjäger, H.; Beutler, P. *J. Chem. Soc., Dalton Trans.* **1979**, 1415.(29) When only the first dissociation constant for [Ir(H₂O)₆]³⁺ was considered, a good fit with the acquired potentiometric data was obtained. However, we were unable to fit the potentiometric data to a second dissociation constant for the hexaaqua ion.

Table 5. Rate Constants and Activation Parameters for Water Exchange on Hexaaqua and Monohydroxy Pentaqua Trivalent Metal Ions (Including Thermodynamic Parameters for the Acid Dissociation of the Hexaaqua Ions)

species	parameter	Ga(III) ^a	Ti(III) ^b	Fe(III) ^c	Cr(III) ^d	Ru(III) ^e	Rh(III) ^f	Ir(III) ^g
[M(H ₂ O) ₆] ³⁺	ionic radius (pm) ^h	62	67	64	61	68	66.5	68
	k_1^{298} (s ⁻¹)	4.0×10^2	1.8×10^5	1.6×10^2	2.4×10^{-6}	3.5×10^{-6}	2.2×10^{-9}	$(1.1 \pm 0.1) \times 10^{-10}$
	ΔH_1^\ddagger (kJ mol ⁻¹)	67.1	43.4	64.6	108.6	89.8	131.2	130.5 ± 0.6
	ΔS_1^\ddagger (J K ⁻¹ mol ⁻¹)	+30.1	+1.2	+12.1	+11.6	-48.2	+29.3	$+2.1 \pm 1.7$
	ΔV_1^\ddagger (cm ³ mol ⁻¹)	+5.0	-12.1	-5.4	-9.6	-8.3	-4.1	-5.7 ± 0.5
	mechanism	I _a	A, I _a	I _a	I _a	I _a	I _a	I _a
	[M(H ₂ O) ₅ (OH)] ²⁺	k_2^{298} (m s ⁻¹)	1.4×10^1		11.4×10^4		1.1×10^{-6}	1.5×10^{-8}
ΔV_2^\ddagger (cm ³ mol ⁻¹)	+7.8		+7.8		-1.1	-2.1	+1.2	-0.2 ± 0.8
pK_a^{298}	3.9		2.9		4.1	2.7	3.5	4.45 ± 0.03
k_{OH}^{298} (s ⁻¹)	1.1×10^5		1.2×10^5		1.8×10^{-4}	5.9×10^{-4}	4.2×10^{-5}	5.6×10^{-7}
k_{OH}/k_1	275		750		75	170	19100	5100
ΔV_a^0 (cm ³ mol ⁻¹)	+1.5		+0.8		-3.8	-3.0	-0.2	-1.5 ± 0.3
ΔV_{OH}^\ddagger (cm ³ mol ⁻¹)	+6.2		+7.0		+2.7	+0.9	+1.5	+1.3
mechanism	I _a		I _a		I	I	I	I

^a Reference 43. ^b Reference 42. ^c References 25 and 27. ^d Reference 9. ^e Reference 22. ^f Reference 11. ^g This work. ^h Reference 44.

ized by Beutler and Gamsjäger in 1976¹⁵ and its coordination number in solution was also determined by these same workers using an ¹⁸O-tracer technique.³⁰ Subsequently, the hexaaqua structure of this complex was verified by a crystal structure obtained on the corresponding caesium sulfate alum CsIr(SO₄)₂·12H₂O.³¹ Despite the fact that almost 20 years have passed since the initial discovery of [Ir(H₂O)₆]³⁺, to date few, if any, kinetic investigations of successfully monitored anation reactions have been reported for this species. Attempts at measuring the water exchange in perchloric acid solutions by an oxygen-18 isotopic dilution method in sealed tubes at 393 K were impaired by oxidation yielding purple solutions believed to contain iridium(IV).¹³ Furthermore, anation of [Ir(H₂O)₆]³⁺ (2.3×10^{-3} M) by either Cl⁻ or Br⁻ ions (3.7 M) was not detected despite the fact the reaction was monitored at 313 K for over 15 days.¹³ In retrospect, this result is not surprising since based on our results the half-life for water exchange at this temperature (313 K) is *ca.* 15 years. Similar studies with thiocyanate were impaired by the competing acid decomposition of thiocyanate at the elevated temperatures and prolonged reaction times required.¹³ This lack of information sponsored the belief that hexaaqua iridium(III) was the most inert metal hexaaqua ion yet obtained and that successful kinetic studies of this complex, including the fundamental process of water exchange, may prove difficult, if not impossible.¹³

The key to solving this problem came during our attempts to enrich the bound water in the hexaaqua ion [Ir(H₂O)₆](ClO₄)₃. Refluxing the iridium salt at 413 K for 24 h in a perchloric acid solution of ¹⁷O-enriched water gave an unwanted purple solution. The spectroscopic data obtained for this solution (¹⁷O NMR (H₂O): -10 ppm (singlet); UV/visible: peak maximum λ (nm) 547 in 1.0 M H⁺) are comparable to those obtained for a purple iridium(IV) solution which has been assigned to a dimeric oxygen-bridged species resulting from electrochemical oxidation of [Ir(H₂O)₆]³⁺ in perchloric acid solution.^{12,14} Notably, repeating our enrichment step using the trifluoromethanesulfonate salt, [Ir(H₂O)₆](CF₃SO₃)₃, gave only the desired ¹⁷O-enriched product, without the formation of the colored solution. This result indicates that the purple iridium(IV) solution mentioned previously is most likely formed as a result of reactions with the perchlorate counterion at these high temperatures.³² Furthermore, a ¹⁷O NMR spectrum obtained of a 5.0 M solution of trifluoromethanesulfonic acid in 3% ¹⁷O-enriched water, after it was refluxed at 423 K for 147 h, showed

(30) Beutler, P.; Gamsjäger, H.; Baertschi, P. *Chimia* **1978**, *5*, 163.

(31) Armstrong, R. S.; Beattie, J. K.; Best, S. P.; Skelton, B. W.; White, A. H. *J. Chem. Soc., Dalton Trans.* **1983**, 1973.

(32) Notably, UV/visible spectroscopy may be used to obtain an estimate of the fraction of Ir(III) oxidized by ClO₄⁻, although such a study was not performed in this work.

no measurable exchange between the CF₃SO₃⁻ oxygen atoms and the bulk water oxygen atoms. Taken together, these results strongly suggested that [Ir(H₂O)₆](CF₃SO₃)₃ was an ideal candidate for a successful water exchange kinetic study and also provided a qualitative estimate of the upper limit for the exchange of CF₃SO₃⁻ with H₂O.

Water Exchange on [Ir(H₂O)₆]³⁺. The inertness of the iridium(III) solvate prevented us from studying its kinetics by the classical NMR line-broadening technique.³³ Instead, the isotopic labeling method was used, employing ¹⁷O NMR spectroscopy to follow the solvent exchange. Accurate rate constants were obtained from fits of resonance integrations to first-order equations; thus, no assumptions about relaxation mechanisms had to be made, as is often the case with line-broadening techniques. Notably, the obvious advantage of NMR spectroscopy over mass spectrometry for the study of slow exchange reactions is that the former technique can be used to discern different kinetic processes as well as the formation of possible side products without the need for previous chemical transformations.

Our *directly* determined value of the water exchange rate constant for [Ir(H₂O)₆]³⁺ (Table 5) is in keeping with *estimated* upper limits for the rate constant of Cl⁻ anation ($<10^{-9}$ M⁻¹ s⁻¹) on this same species.¹³ Previous substitution studies on the t_{2g}⁶ analogs [Co(H₂O)₆]³⁺³⁴ and [Rh(H₂O)₆]³⁺³⁵ have indicated an increase in inertness in going from Co³⁺ to Rh³⁺ and then to Ir³⁺ which is in keeping with the effect of increasing ligand-field stabilization.³⁶ A similar overall trend has been observed for H₂O exchange of the aquapentaammine complexes [Co(NH₃)₅(H₂O)]³⁺,^{37,38} [Rh(NH₃)₅(H₂O)]³⁺,^{38,39} and [Ir(NH₃)₅(H₂O)]³⁺.⁴⁰

The negative volume (-5.7 cm³ mol⁻¹) and near zero entropy ($+2.1$ cm³ mol⁻¹) of activation obtained for [Ir(H₂O)₆]³⁺ (Table 5) is supportive of an associative pathway for the water exchange process on this species. However, to differentiate between an associative interchange I_a and a limiting associative A mechanism, the magnitude of ΔV^\ddagger must be considered. Its value is less negative than that calculated by Swaddle *et al.* for first-row metal ions for an associative A mechanism (-13.9 cm³

(33) (a) Merbach, A. E. *Pure Appl. Chem.* **1982**, *54*, 1479. (b) Merbach, A. E. *Pure Appl. Chem.* **1987**, *59*, 161.

(34) Conocchioli, T. J.; Nancollas, G. H.; Sutin, N. *Inorg. Chem.* **1965**, *5*, 1.

(35) Swaminathan, K.; Harris, G. M. *J. Am. Chem. Soc.* **1966**, *88*, 4411. (36) Basolo, F.; Pearson, R. G. In *Mechanisms of Inorganic Reactions*; Wiley: New York, 1967; p 145.

(37) Hunt, H. R.; Taube, H. *J. Am. Chem. Soc.* **1958**, *80*, 2642.

(38) Gonzalez, G.; Moullet, B.; Martinez, M.; Merbach, A. E. *Inorg. Chem.* **1994**, *33*, 2330.

(39) Swaddle, T. W.; Stranks, D. R. *J. Am. Chem. Soc.* **1972**, *94*, 8357.

(40) Tong, S. B.; Swaddle, T. W. *Inorg. Chem.* **1974**, *13*, 1538.

mol⁻¹)⁴¹ and, more importantly, significantly less negative than the most negative experimental value (Ti³⁺, -12.1 cm³ mol⁻¹).⁴² Thus, the water exchange mechanism on the hexaaqua iridium(III) species is best represented as an associative interchange mechanism I_a. A similar mechanism has been assigned to the trivalent metal hexaaqua ions Fe³⁺, Cr³⁺, Ru³⁺, and Rh³⁺ (Table 5). In contrast, water exchange on the hexaaqua gallium(III) ion [Ga(H₂O)₆]³⁺ has been suggested to proceed by a dissociative interchange I_d process where filled orbitals, size of the metal ion, and electrostatics are believed to determine the pattern of behavior observed.⁴³

It is clear from the literature covering the kinetics of homoleptic hexaaqua ions that properties such as charge, ionic radius, and electron distribution in the valence orbitals are important contributors to the mechanism of water exchange on the respective aqua species.²⁴ Therefore, for a meaningful discussion we will focus our comparisons of [Ir(H₂O)₆]³⁺ to ruthenium(III) and its second-row analog rhodium(III), especially in light of the fact that other third-row trivalent hexacoordinated aqua ions have yet to be characterized.

Regardless that the ionic radii for Ir³⁺ (68 ppm, t_{2g}⁶)⁴⁴ and Ru³⁺ (68 ppm, t_{2g}⁵)⁴⁴ are identical, the latter species exhibits greater associative character than the former (Table 5). This may be attributable to the larger electronic population on Ir³⁺ which disfavors the approach of a seventh water molecule at the transition state, diminishing its associative character compared to that of Ru³⁺. Notably, Ir³⁺ exhibits greater associative character than its valence isoelectronic ruthenium partner Ru²⁺ (73 ppm, t_{2g}⁶),²² despite the larger ionic radius of the latter ion. This result is attributed to the decrease in charge on going from iridium to ruthenium which will disfavor nucleophilic attack and lead to a weakening of the metal water bond. This latter comparison suggests that the charge of a hexaaqua ion may be a larger contributor to the mechanism of water exchange than the ionic radii of the respective metal ion. The kinetic data also indicates that Ir³⁺ behaves in a more associative manner than its analog Rh³⁺ (66.5 pm, t_{2g}⁶)⁴⁴ despite the larger overall electronic population on Ir³⁺. This behavior is ascribed to the larger ionic radius for Ir³⁺, which is not completely compensated for by the lanthanide contraction, and thus facilitates the approach of a water molecule at the transition state.

Water Exchange on [Ir(H₂O)₅(OH)]²⁺. The hydrolysis in water of trivalent hexaaqua ions of the form [M(H₂O)₆]³⁺ is a kinetically important process since it results in the production of a significant amount of the conjugate base [M(H₂O)₅(OH)]²⁺ (eq 6). The presence of this species can then lead to an alternative pathway for water exchange.

The water exchange rate constant obtained for the monohydroxy pentaqua ion of iridium [Ir(H₂O)₅(OH)]²⁺ (5.6 × 10⁻⁷ s⁻¹) is considerably larger than that measured for the corresponding parent ion [Ir(H₂O)₆]³⁺ (1.1 × 10⁻¹⁰ s⁻¹), and more importantly, this increase in the rate constant is also accompanied by an increase in dissociative character toward a more positive volume of activation. Similar behavior has been reported for all the monohydroxy pentaqua metal ions (Table 5). This drastic mechanistic difference between both exchange pathways is most plausibly ascribed to the strong electron-

donating capability of HO⁻ which is responsible for strengthening the bond between it and the metal center while concomitantly weakening the remaining metal-water bonds. Thus the ligated water molecules become more labile which, in turn, favors a dissociative activation process. This mechanistic change is most pronounced for Fe(III) where a changeover from I_a for [Fe(H₂O)₆]³⁺ to I_d for [Fe(H₂O)₅(OH)]²⁺ was reported (Table 5). This mechanistic change toward dissociation is less pronounced in [Ir(H₂O)₅(OH)]²⁺ as evidenced by the near zero value for the volume of activation for this species. Small positive values of ΔV_{OH}[‡] were obtained for the corresponding ruthenium and rhodium monohydroxy pentaqua species as well (Table 5). These results indicate that both bond making and bond breaking contribute equally to the transition state (within experimental error) and are therefore supportive of an interchange I mechanism for water exchange on [Ir(H₂O)₅(OH)]²⁺.

The extrapolated water exchange rate constant at 298 K for [Ir(H₂O)₆]³⁺ is *ca.* 20 times slower than that for [Rh(H₂O)₆]³⁺ (Table 5). This trend is even more pronounced for the corresponding monohydroxy species where the rate constant for water exchange at 298 K for [Ir(H₂O)₅(OH)]²⁺ is *ca.* 75 times slower than that for [Rh(H₂O)₅(OH)]²⁺ (Table 5). Furthermore, in reality this pathway is actually closer to 3 orders of magnitude slower in acidic media due to a further 1 order of magnitude difference in the respective pK_a values (Table 5). The poorer labilizing effect demonstrated by the HO⁻ ligand in [Ir(H₂O)₅(OH)]²⁺ may be ascribed to the larger electronic population on Ir³⁺, which may suppress effective σ-donation from the bound OH⁻. The high energy of the σ-accepting e_g orbitals, resulting from a larger ligand field splitting energy for the Ir³⁺ ion, may also minimize the capability of the HO⁻ ligand to labilize the remaining bound water molecules on [Ir(H₂O)₅(OH)]²⁺.

Conclusion

This work provides the first definitive quantitative evidence for water exchange on iridium(III). The rate constants and activation parameters for water exchange on hexaaqua and monohydroxy pentaqua iridium(III) have been determined by ¹⁷O NMR spectroscopy as a function of temperature (358–406 K) and pressure (0.1–210 MPa) at several acidities (0.5–5.0 *m*). It is important to note that in all cases noncoordinating trifluoromethanesulfonate (CF₃SO₃⁻) was used as the counterion. The water exchange rate constant for [Ir(H₂O)₆]³⁺ was calculated to be 1.1 × 10⁻¹⁰ s⁻¹ (residence time of *ca.* 300 years), corresponding to the *slowest* documented water exchange at a homoleptic mononuclear metal center to date. The negative volume and near zero entropy of activation for the water exchange on [Ir(H₂O)₆]³⁺ are supportive of an associative interchange I_a mechanism.

Estimations of the rate constant and activation volume for water exchange on [Ir(H₂O)₅(OH)]²⁺ indicate that this species is much more reactive and has more dissociative character than the hexaaqua ion, as is the case for other pairs of trivalent hexaaqua and monohydroxy pentaqua ions.

Acknowledgment. We thank the Swiss National Science Foundation for a visiting position for D. T. R. and for financial support. The authors are also indebted to Dr. G. Laurency for helpful discussions along with Mr. R. Ith for technical assistance.

JA954071N

(41) Swaddle, T. W. *Inorg. Chem.* **1983**, *22*, 2663.

(42) Hugi, A. D.; Helm, L.; Merbach, A. E. *Inorg. Chem.* **1987**, *26*, 1763.

(43) Hugi-Cleary, D.; Helm, L.; Merbach, A. E. *J. Am. Chem. Soc.* **1987**, *109*, 4444.

(44) Shannon, R. D. *Acta Crystallogr., Sect. A* **1976**, *32*, 751.